

Berkeley 30 Jets

Specifications

Seating Capacity	6 Adults
Dimensions	78" x 78" x 36" (198 cm x 198 cm x 91 cm);
Dry Weight	386 lbs (175 kg)
Filled Weight (Spa Volume)	3,864 lbs (1,753 kg)
Filled Weight (Average Fill)	2,971 lbs (1,348 kg)
Water Capacity (Spa Volume)	417 US gallons (1,579 Liters)
Water Capacity (Average Fill)	310 US gallons (1,173 Liters)
Electronic Controls	Digital Touch Controller. Offers customizing of cleaning cycles and water temperature setting.
Pump 1	North America (60 Hz): 2-Speed, 3.0 HPR continuous
Export (50 Hz):	2 kW, 2-Speed
Pump 2	N/A
Export (50 Hz):	N/A
Circulation Pump	N/A
Total Jets	30
Seat A Jets	6 DirectionalMax1, 6 DirectionalMax2
Seat B Jets	1 DirectionalMax1
Seat C Jets	6 DirectionalMax2
Seat D Jets	2 DirectionalMax1
Seat E Jets	4 DirectionalMax1, 2 DirectionalMax2
Seat F Jets	1 DirectionalMax1
Footwell (G)	2 DirectionalMax1
Massage Selectors	N/A
Air Controls	2
Water Management System	One Easy Kleen 30 ft ² filter cartridge; Optional factory installed Ozone
Export (50 Hz):	Optional factory installed Ozone
LED Lighting	Multicolor Waterfall light; Footwell light, Exterior corner lights (8 qty)
Shell/Cabinet Colors	Mystic Sparkle, Tuscan Sparkle, Night Sparkle, Glacier Sparkle
Headrests	3
Waterfalls	One with independent flow rate (on or off) adjustment; powered by pump 1
Heater:	Hi Flow 1.0kW/4kW
Export (50 Hz):	Hi Flow 3.0kW
Electrical Requirements:	North America (60 Hz): Convertible 120 VAC@15A or 240 VAC@30A, 40A
	Export (50 Hz): 230-240V@1x16A, 1X32A
Warranty*	North America (60 Hz): Shell - 5 Years (date of purchase) or 6 Years (date of manufacture) Electrical Components - 1 Year (date of purchase) or 2 Years (date of manufacture) Plumbing Components - 1 Year (date of purchase) or 2 Years (date of manufacture) Cover - 1 Year (date of purchase) or 2 Years (date of manufacture) Labor - 1 Year (date of purchase) or 2 Years (date of manufacture)
	Export (50 Hz): Spa Shell - 5 Years (date of purchase) or 5 Years and 6 months (date of manufacture) Electrical Components - 2 Years (date of purchase) or 2 Years and 6 months (date of manufacture) Plumbing Components - 2 Years (date of purchase) or 2 Years and 6 months (date of manufacture) Cover - 2 Years (date of purchase) or 2 Years and 6 months (date of manufacture) Labor - 2 Years (date of purchase) or 2 Years and 6 months (date of manufacture)
Special Features	Optional Suite Package Add-On



*(See Warranty Document for Specific Details)

Dimensions/Specifications are Subject to Change Without Notice

Berkeley 30 Jets

Massage Selector/Air Control Diagram

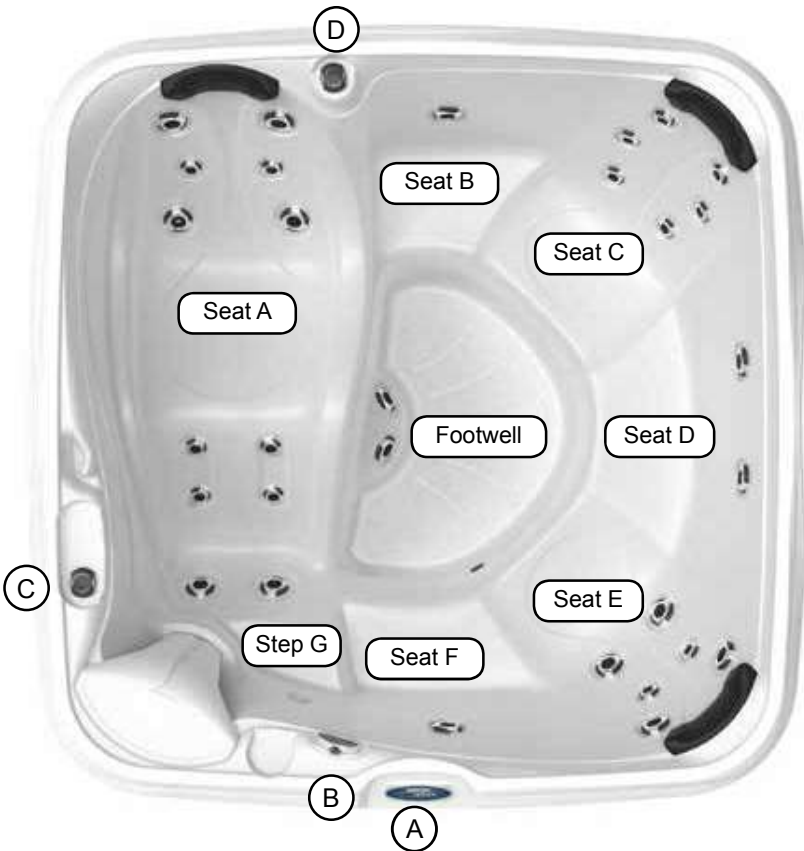

- (A) Topside Control - Activate Jet Pump, Light and Control Water Temperature
- (B) Water Feature Control - Controls Water Feature Output.
- (C) Air Control - Activates Seat A Jets (6 DirectionalMax1 Jets, 6 DirectionalMax2 Jets)
- (D) Air Control - Activates Seat B Jets (1 DirectionalMax1 Jet), Seat C Jets (6 DirectionalMax2 Jets), Seat D Jets (2 DirectionalMax1 Jets), Seat E Jets (4 DirectionalMax1 Jets, 2 DirectionalMax2 Jets), Seat F Jets (1 DirectionalMax1 Jet), Footwell Jets (2 DirectionalMax1 Jets)

- Jet Pump 1: All seats and footwell jets

30 Total Jets

DirectionalMax1
Jets (16)

DirectionalMax2
Jets (14)



Spa Operation Subject to Change without Notice

Seat Depths

Listed dimensions represent distance from top of spa to lowest point in seat.
Tolerance: $\pm 0.5"$ (1.27 cm)

- A = 25.75" (65.40 cm)
- B = 24.50" (62.23 cm)
- C = 28.00" (71.12 cm)
- D = 24.75" (62.86 cm)
- E = 26.50" (67.30 cm)
- F = 23.25" (59.06 cm)
- G = 19.00" (48.26 cm)
- H = 34.50" (87.63 cm)

Dimensions/Specifications are Subject to Change Without Notice



Berkeley 30 Jets

Dimensions

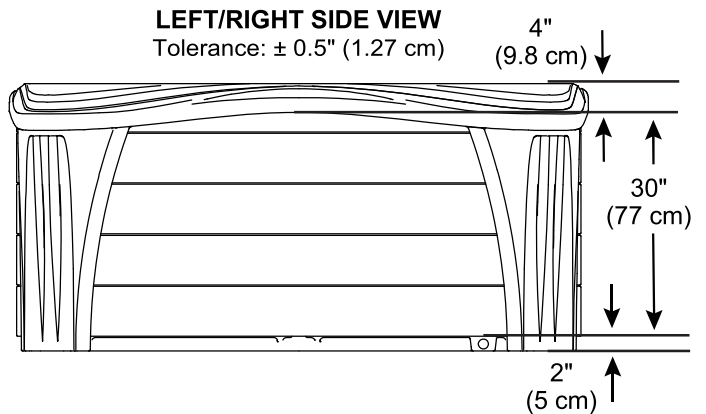
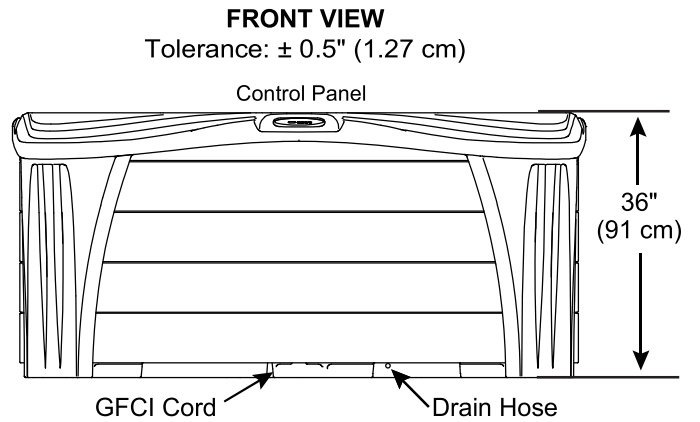
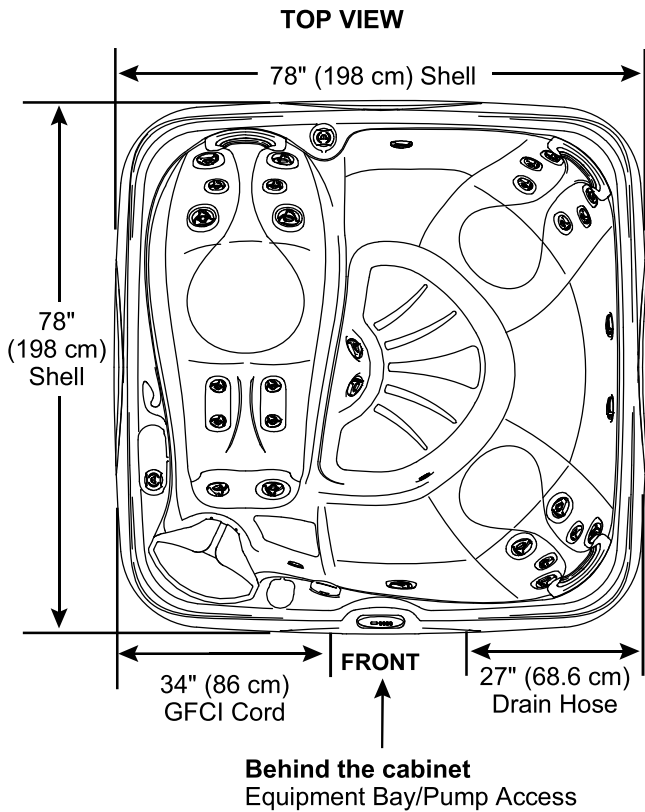

IMPORTANT! Always measure each hot tub for exact dimensions BEFORE designing its foundational support and/or decking.

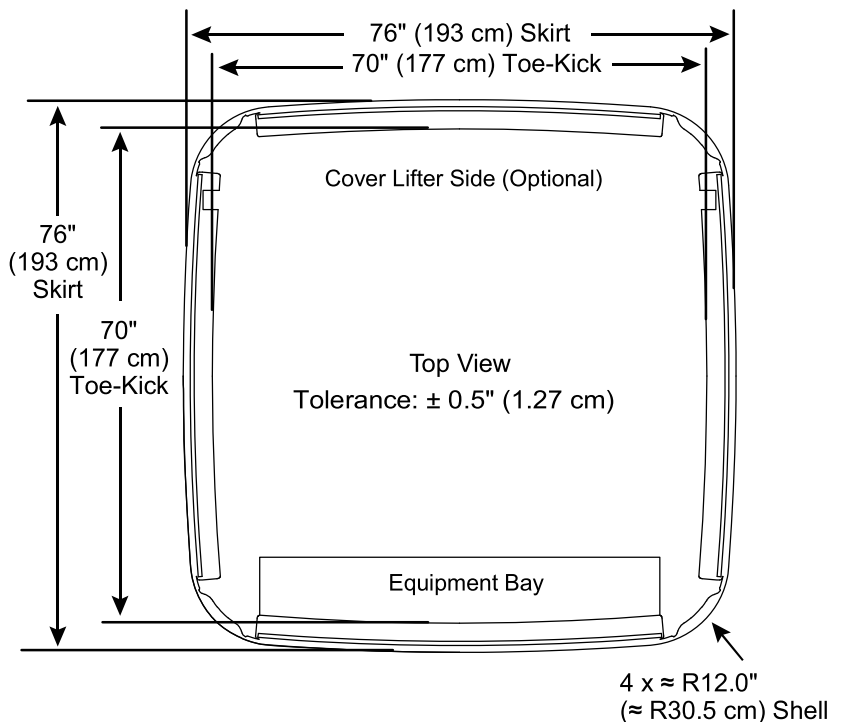

Dimensions/specifications subject to change without notice. Tolerance $\pm 0.5"$ (1.27 cm)